



Model: INVISIBLE MOUNT FOR iPad MINI WO.GRILLS

Family: WALL-SMART

DWG NO. 002-4-607-NG-SPC

Model No.: 002-1-607-NG

PRODUCT SPEC.

REVISION A

DATE 09/FEB/2020



Make Your Wall Smart

“INVISIBLE MOUNT FOR iPad MINI WO.GRILLS” - Product description:

The “INVISIBLE MOUNT FOR iPad MINI WO.GRILLS” is an adapter for in-wall flush installation of iPad mini™.

The “INVISIBLE MOUNT FOR iPad MINI WO.GRILLS” firmly mounts the iPad mini™ while allowing easy insertion, removal and operation.

Key features and benefits:

- Flush with the wall.
- Wall mount may be mounted in any orientation.
- The iPad home button remains accessible.
- The wall mount contains NO speaker and mic. grills.
- Paintable with the wall paint in any color and texture.
- Allows easy insertion and removal of the iPad.
- The adapter is supplied unpainted (To be painted after installation as part of the wall).
- Designed to be installed in ½” drywall. Installation of the Wall-Smart adapter is straightforward. Installation process is similar to drywall construction procedures.
- For installation in concrete/block wall use “WS CONCRETE ADAPTOR 284X205” P/N 100-1-618 (sold separately) according installation instruction 10-04-00103-INS in <http://www.wall-smart.com/faq>
- Designed for the use with iPad mini 5 (by Apple) (iPad is not included).
- Adapter kit contains:
 1. (X1) Wall adapter;
 2. (X2) Wall-Smart rubber pads;
 3. (X1) Wall-Smart Pad Positioning Template

Key properties:

- Dimensions: (W/H/D): 281.9mm (11.09")/ 203.2mm (8")/ 39.9mm (1.57")
- Power Supply: Wall mount includes POE to USB converter.

The installer should connect the wall mount to an IEEE 802.3at POE+ power source via CAT6 cable and RJ45 connector.
(Please verify the power source can supply up to 25.5W)
- Weight: 0.8Kg, 1.76lbs.
- Material: Moisture resistant MDF
- To be installed in ½” drywall (for installation in 5/8” drywall use 1/8” shim pack P/N 10-01-067 (sold separately)).

iPad® is a trademark of Apple Inc., registered in the U.S. and other countries.

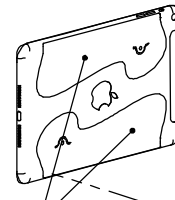
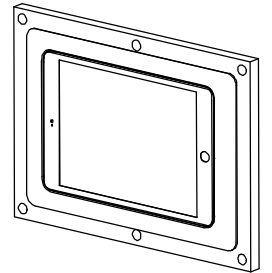
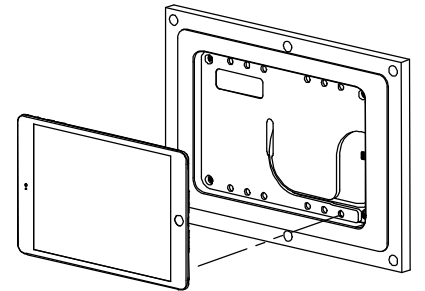
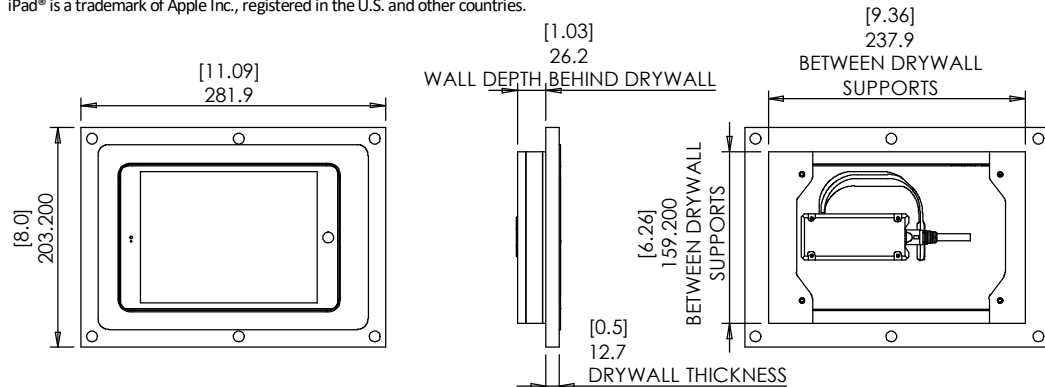

WALL-SMART RUBBER PADS

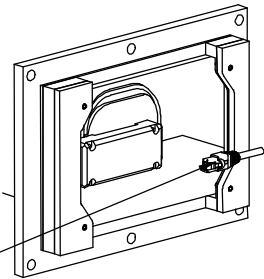

CONNECT POE CABLE

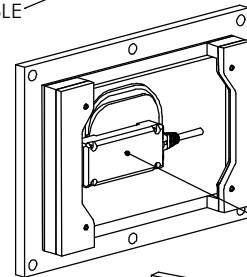

POE TO USB CONVERTER

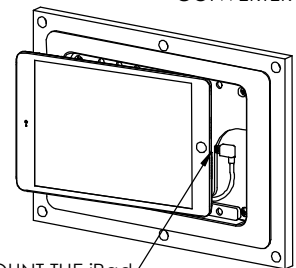

TO MOUNT THE iPad INSERT CONNECTOR AND MAGNETICALLY DROP iPad IN PLACE.

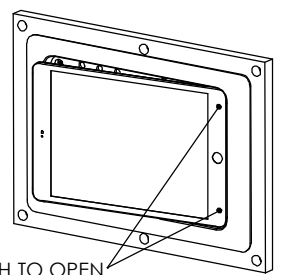

PUSH TO OPEN



Model: INVISIBLE MOUNT FOR iPad MINI WO.GRILLS

Family: WALL-SMART

DWG NO. 002-4-607-NG-SPC

Model No.: 002-1-607-NG

PRODUCT SPEC.

REVISION A

DATE 09/FEB/2020



Wall mount installation in drywall:

- Before installing the wall mount, make sure a POE cable is routed to the installation area.
- Preferably, connect POE cable to the wall mount POE to USB converter before installation. See page 4 of this document for details.
- The wall mount is supplied with a protective plug covering the front wall mount opening. Remove plug only after finished painting.
- Perform at least level 4 drywall finish per ASTM C 840.
- In case of level 5 finish (skim coat), mask adaptor opening during skim coat application and sand adaptor front surface until front adaptor edge is visible clean green.
- In case a wall-mount that was designed for 1/2" drywall should be installed in 5/8" drywall, you may use "WS 1/8" Shim pack" P/N 10-01-067 (sold separately).
- Make sure the adaptor is installed on firm supports. A good practice would be to apply construction adhesive between adapter and supports.
- In some cases, it is convenient to use "Telescoping box mounting brackets" (BB2-16T/24T by Cooper Industries plc \ Cooper B-line) or "Telescoping Screw Gun Box Bracket" (TSGB16/24 by ERICO International Corporation) for supports.
- Apply setting-type compound to gaps between adapter and drywall.
- Apply fine premixed drywall joint compound and drywall paper tape (not a mesh tape).
- Avoid applying joint compound to the wall mount front surface. Sand off joint compound covering front wall mount surface.
- Let the setting-type compound and joint compound + paper tapes to dry over night.
- Apply 1st drywall joint compound layer and let dry over night.
- Apply 2nd drywall joint compound layer and let dry over night.
- In some cases as 3rd drywall joint compound layer is required for touch-up.
- Avoid heating installation point by blowers. Let joint compound dry in ambient room temperature.
- Avoid washing the wall during installation. Damp cloth may be used to clean the area.
- Sand adaptor and drywall compound using fine sand paper until front surface of the adaptor is visible clean green.
- Before painting, remove grill protective labels.
- Avoid plugging speaker and mic. grills with paint.
- Avoid spray painting. Do not paint internal surfaces.
- Before inserting the iPad into the wall mount, clean the wall mount internal surfaces of any joint compound or paint.
- Before inserting the iPad, adhere "Wall-Smart rubber pads" to the back of the iPad according to page 3 of this document.

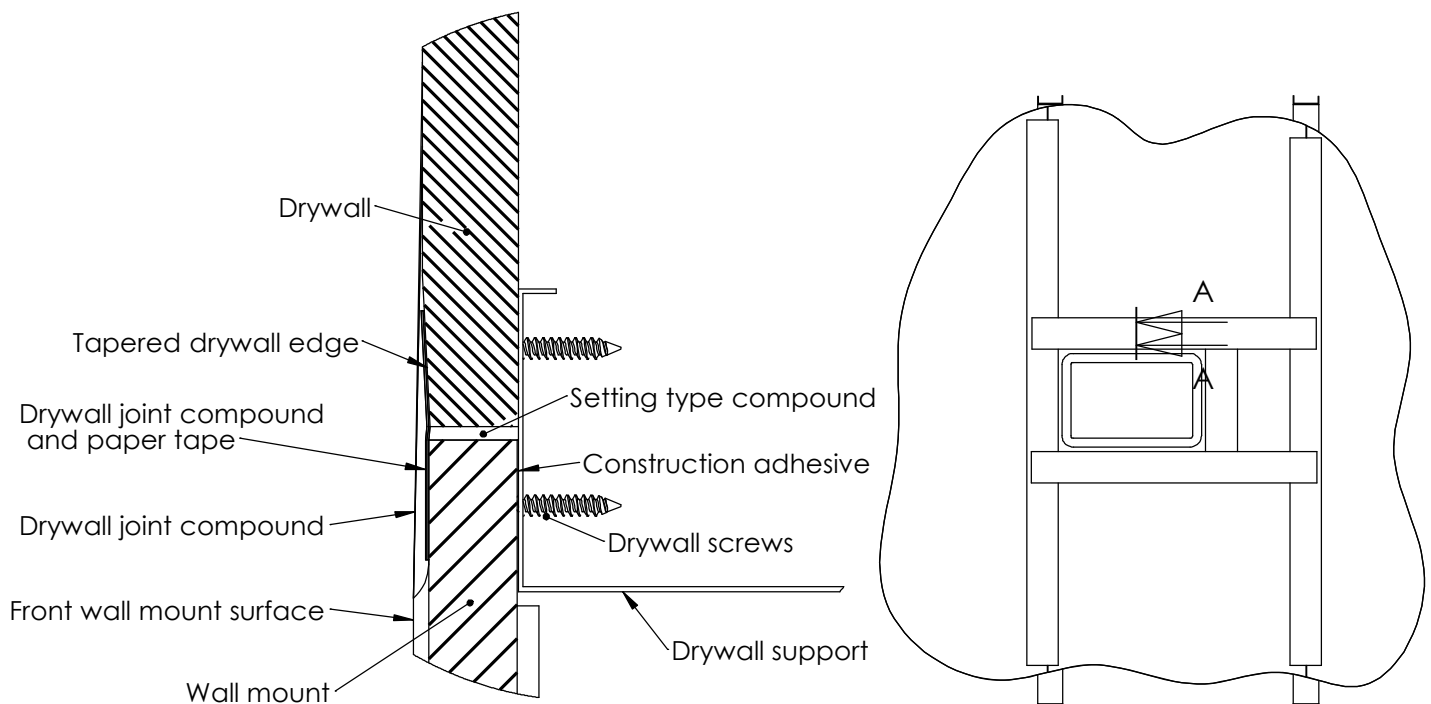



Model: INVISIBLE MOUNT FOR iPad MINI WO.GRILLS

Family: WALL-SMART

DWG NO. 002-4-607-NG-SPC



Model No.: 002-1-607-NG

PRODUCT SPEC.

REVISION A

DATE 09/FEB/2020

Wall-Smart rubber pads installation:

1. Clean iPads back surface.

2. Position template.

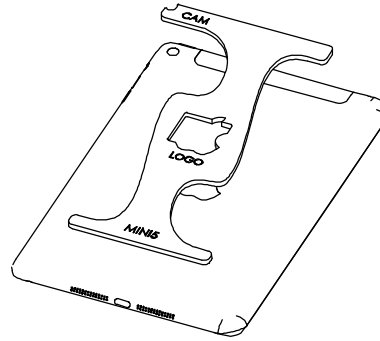

3. Align template cutouts with Apple logo and cam .

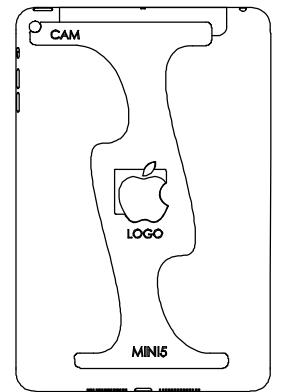

4. Remove protective tape of a rubber pad back adhesive .

5. Align rubber pad to template while maintaining the position of the template .

6. Adhere the rubber pad to the iPad gradually from template to the iPad edge .

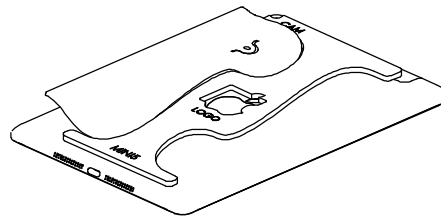

7. Press down from the center of the rubber pad and towards the pad edges to remove air bubbles .

8. Push down the edges of the rubber pad to close all gaps .

9. Repeat steps 4-8 for the second rubber pad .

10. Remove the template and wait 6mins before mounting.

